

AWWA C515

Resilient Seat GATE VALVES

Model 2030 OS&Y

UNITED BRAND



APPROVED



Available:

- Flange Ends
- Grooved Ends
- Flange x Groove

Description:

1. Conforms to AWWA C 515
2. Epoxy coated inside and outside to AWWA C550.
3. Working Pressure: 300 psi
4. Temperature: -10° to 120°C
5. Flanged Ends conform to ANSI B16.1 standard.
5. Grooved Ends conform to AWWA C606 standard.

MATERIAL LIST

ITEM NO.	DESCRIPTION	MATERIAL
1	Handwheel	Ductile Iron, ASTM A536
2	Stem Nut	B62
3	Packing	Graphite - Non-asbestos
4	Gasket	EPDM
5	Bonnet	Ductile Iron, ASTM A536
6	Stem	420 Stainless Steel
7	Wedge Nut	304 Stainless Steel
8	Wedge	Ductile Iron, ASTM A536 w/EPDM Coating
9	Body	Ductile Iron, ASTM A536
10	Test Plug	Brass, C36000

Design and materials are subject to change without notice.

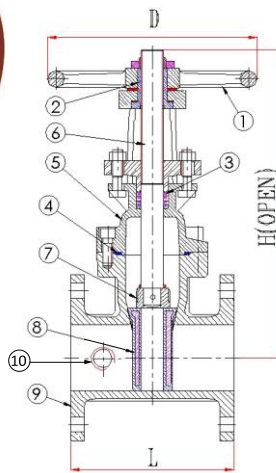

Flanged

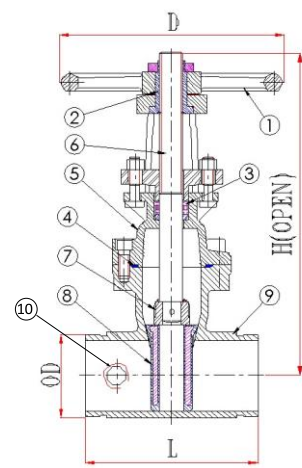

Grooved

DIMENSIONAL DATA

Size	Part No. (Flanged)	L	H	D	Part No. (Flange x Grooved)	L	H	D	Part No. (Grooved)	L	H	D	Turns To Open
2-1/2"	2030FF-125	7-1/2	16-3/8	7-1/2	2030FG-125	7-1/2	16-3/8	7-1/8	2030GR-125	7-1/2	16-3/8	7-1/8	9
3"	2030FF-130	8	18-1/8	10	2030FG-130	8	18-7/8	10	2030GR-130	8	18-7/8	10	11
4"	2030FF-140	9	21-5/8	10	2030FG-140	9	21-5/8	10	2030GR-140	9	21-5/8	10	16
5"	2030FF-150	10	25-3/8	12	2030FG-150	10	25-3/8	12	2030GR-150	10	25-3/8	12	16
6"	2030FF-160	10-1/2	29-1/8	12	2030FG-160	10-1/2	29-1/8	12	2030GR-160	10-1/2	29-1/8	12	19
8"	2030FF-180	11-1/2	36-5/8	14	2030FG-180	10-1/2	36-5/8	14	2030GR-180	10-1/2	36-5/8	14	26
10"	2030FF-200	13	44-1/2	17-1/2	2030FG-200	13	44-1/2	17-1/2	2030GR-200	13	44-1/2	17-1/2	32
12"	2030FF-220	14	52	17-1/2	2030FG-220	14	52	17-1/2	2030GR-220	14	52	17-1/2	38
16"	2030FF-260	16	70-1/3	21 1/16									

Dimensions in inches

900 Industries, Inc.

16 Deborah Drive, Sutton, MA 01590 U.S.A. Tel:
(800) 225-7288 • Fax: (508) 865-7336

0311